



Ruud® L-Series Super High-Efficiency Condensing Combi Boilers

Flexible Installation

- Moveable combustion air intake (left/right) and ability to flex vent in existing B-vent
- Extra long pipe fittings with notched sides for easy gripping with wrench
- Only 5 moving parts – Fan, Bypass Valve, Pump, Gas Valve, and Damper
- Universal shared platform parts – Easily diagnose and service with common parts for all L-Series units

Key Features

- Innovative Labyrinth Heat Exchanger with 2 independent copper waterways for maximum heat transfer and minimal heat loss

- Built-in ECM variable speed, high efficiency boiler pump
- Built-in Illuminated Touchscreen Control Panel
- Outdoor reset technology increases efficiency by lowering water temperature automatically
- Wireless cascading using RF balances workload of each unit for longer life
- Only Combi Boilers that can be cascaded for both space heating and domestic hot water
- ENERGY STAR® certified with up to 96% AFUE and ASME-rated (excludes 160K combi model).

Specifications

MODEL NO.		CRUCBH-L99i	CRUCBH-L125i	CRUCBH-L160i	CRUCBH-L199i
Input Rate (Heating Mode)	MAX	99,000 BTU/h	99,000 BTU/h	125,000 BTU/h	125,000 BTU/h
	MIN	15,500 BTU/h	16,500 BTU/h	23,000 BTU/h	28,500 BTU/h
Output Rate (Heating mode)	MAX	89,000 BTU/h	89,000 BTU/h	111,000 BTU/h	111,000 BTU/h
	MIN	14,800 BTU/h	15,800 BTU/h	22,000 BTU/h	27,100 BTU/h
Input Rate (Domestic Hot Water)	MAX	99,000 BTU/h	125,000 BTU/h	160,000 BTU/h	199,000 BTU/h
	MIN	15,500 BTU/h	16,500 BTU/h	23,000 BTU/h	28,500 BTU/h
AFUE		96%	95%	94%	95%
Gas Pressure (Nat Gas or LP gas)	MAX	14" WC			
	MIN	4" WC			
Power Supply		120V/60Hz			
Weight lbs. (empty)		85		84	
Pressure vessel water content – USG		0.5		0.19	
Boiler Flow Rate - GPM	MAX	10		11	
	MIN	2			
Water Pressure	MAX	DHW 150 psi / Heating 43.5psi			
	MIN	DHW 40psi / Heating 8psi			
Maximum Altitude		10,100 ft	10,100 ft	10,100 ft	10,100 ft ³
Ambient temperature – Low (°F)		32°			
Ambient temperature – High (°F)		122°			
Max relative humidity (non-condensing)		90%			
Temp Range	Heating Mode	51°F-194°F			
	Domestic Hot Water	105°F-149°F			
Minimum Activation Flow Rate (DHW)		0.5 GPM			
Gallons per Minute - GPM (Domestic Hot Water)	MAX	4		7	
	67°F Rise	2.4	3.2	4.1	5
Gas Connection		3/4" Male NPT			
Domestic Hot Water Connection		3/4" Male NPT			
Heating Connection		1" Male NPT			
Max equivalent vent length 2" (each side) ²		65'			
Max equivalent vent length 3" (each side)		120'			
Ultra Low NOx		Meets 14ng/J NOx requirements - SCAQMD Rule 1146.2 compliant			
Warranty ¹		10-Year Heat Exchanger, 5-Year Parts, 1-Year Labor			

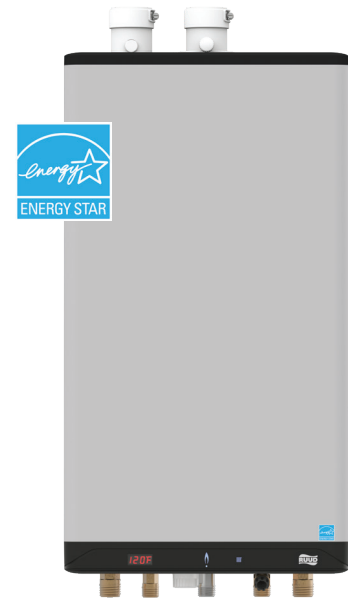

CRUCBH-L125i, CRUCBH-L160i & CRUCBH-L199i
 Indoor Direct Vent
 99,000-199,000 BTU/h
 Natural Gas/LP Convertible



Water heater pressure drop – L-Series
CRUCBH-L99i, CRUCBH-L125i, CRUCBH-L160i & CRUCBH-L199i

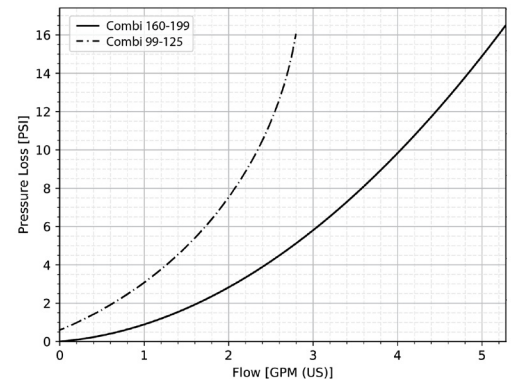

¹See Warranty Certificate for complete information. ²Approximate input derate of 10 - 16% at 2" maximum vent length. ³Natural Gas only, LP is 7,800 ft

CRUCBH L-Series Combi Boilers



View the boiler head loss – L-Series CRUCBH-L99i, CRUCBH-L125i, CRUCBH-L160i & CRUCBH-L199i

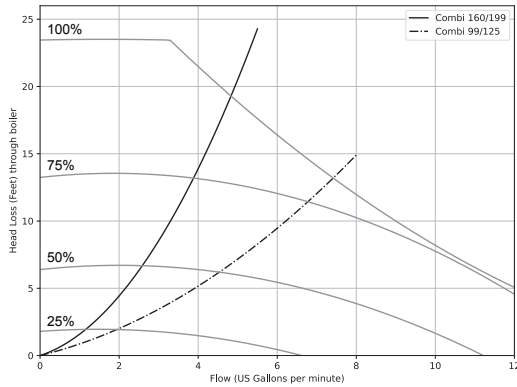

Specifications

VENTING	MAXIMUM EQUIVALENT LENGTH
ULC-636 PVC, CPVC or Polypropylene	(each side)
2"	65' ²
3"	120'
2" or 3" 90° Long Sweep Vent Elbow	Allow 5 equivalent feet
2" or 3" 90° Short Sweep Vent Elbow	Allow 8 equivalent feet
2" or 3" 45° Vent Elbow	Allow 3 equivalent feet
Polypropylene	
PPs 87-90° Elbow	Allow 8 equivalent feet
Flex PPS	
3" PPs Flex	35' Actual (Equivalent = Actual x 1.4)

² Approximate input derate of 10 - 16% at 2" maximum vent length.

SURFACE	MIN. DISTANCE FROM COMBUSTIBLE SURFACES	RECOMMENDED DISTANCE FOR INSTALLATION AND SERVICE
Front	2"	24"
Rear	0"	0"
Left Side	1.5"	6"
Right Side	4"	6"
Top	2"	24"
Bottom	8"	24"

	PIPING CONNECTIONS	DIMENSION
A	Exhaust Outlet	2" Schedule 40 PVC
B	Combustion Air Inlet	2" Schedule 40 PVC
C	Cold Domestic Water Connection	3/4" Male NPT
D	Hot Domestic Water Connection	3/4" Male NPT
E	Heating Water Inlet	1" Male NPT
F	Heating Water Outlet	1" Male NPT
G	Gas Inlet	3/4" Male NPT
H	Condensate Outlet	3/4" Hose
I	Control Wiring	7/16" Rubber Plug

Parts & Accessories

Floor Stand P-267C	Service Parts Kit P-911R	EZ Pipe Manifold 251-063, 251-064	2" PVC Sidewall Vent Kit P-741	3" PVC Sidewall Vent Kit P-742

Dimensions

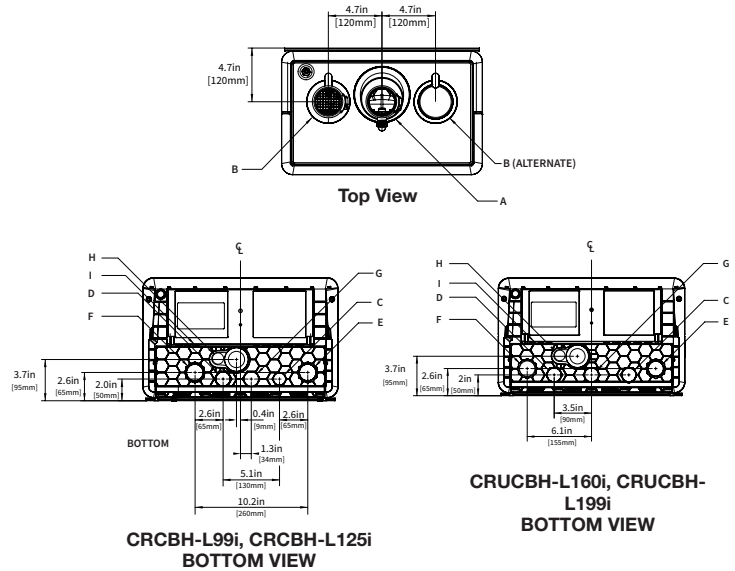
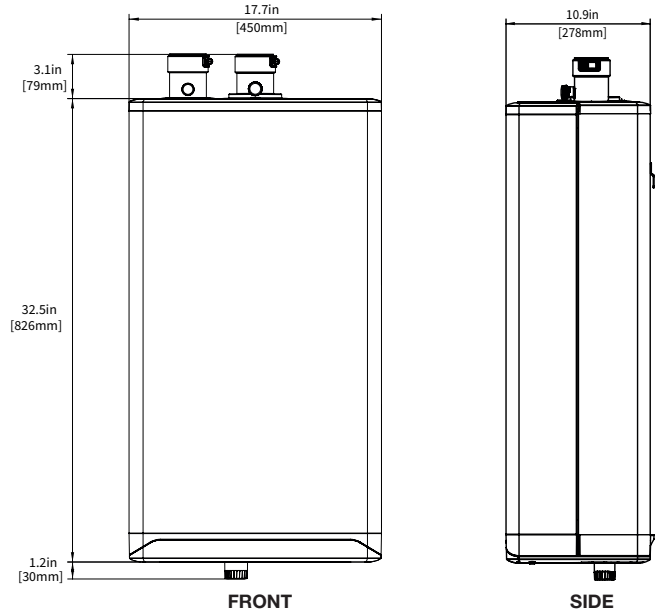

In keeping with its policy of continuous progress and product improvement, Ruud reserves the right to make changes without notice.